

Ikegami

GIVING NEW VALUE TO IMAGES

High Resolution True Day / Night Dome Camera

ICD-609P [PAL]

ICD-609 [NTSC]



540/570TVL

0.8/0.08LUX/f1.2 (Type31)

52dB

2.9-10mm/9-22mm



True Day/Night dome camera designed to have an aesthetic appearance with excellent picture quality, exceptional functionality and high reliability.

Ikegami, the worlds leading company in the field of high quality broadcast and professional video production equipment, is proud to announce the 'ICD-609P/609' True Day/Night Family of Static Domes. They have high resolution, a massive 540TVL (Colour mode) and 570TVL (Monochrome mode), plus the added benefit of True Day/Night changeover function equipped with a Varifocal auto iris lens and are available in a standard internal housing or a vandal resistant housing. They have higher sensitivity at low light levels when the cameras will automatically switch to a Monochrome output for improved low light performance.

Super Dome Colour Camera

Designed to be unobtrusive and not conflict with the aesthetic properties of commercial and residential areas, the ICD-609P/609 comes complete with internal polycarbonate housing or in a vandal resistance aluminum housing.

0.037Lux, True Day/Night Change-over Function

Well designed moving IR cut filter system, inter-connected with the Automatic Gain Control system makes the ICD-609P/609 the ideal Day/Night camera, capable of providing a high quality crisp picture reproduction with 570TVL horizontal resolution under ultra low light conditions down to an amazing 0.08lux/f1.2 (Type31) and 0.12lux/f1.5 (Type92) minimum scene illumination performance.



Color mode *



Monochrome mode *

540/570TVL, High-Resolution Pictures

DSP-based detail correction function results in a sharper image and better Signal-to-Noise ratio. The horizontal resolution is as high as 540TVL in the colour mode and as high as 570TVL in monochrome mode.

52dB, High Picture Quality and Low Smear and Noise

The improved DSP circuit permits more than 52dB Signal-to-Noise ratio with good performance of -110dB vertical pixel overload protection.

Built-in Varifocal with DC drive Iris control

Equipped with a choice of Varifocal lenses to meet the needs of most installations. Two types of Varifocal lenses are available, either a 2.9-10mm or a 9-22mm can be supplied.

Focus EZ Function

Just press the button located at the back of the unit, and the auto iris lens aperture will be kept open even in broad daylight. This ensures that an accurate focus can be set with the best depth of field.

Wide Auto White Balance

The unit is also provided with automatic tracking white balance control (ATW). Improved tracking colour range can be used under different lighting conditions such as Sodium light.

* Not Actual Image.

High Resolution True Day / Night Dome Camera

ICD-609P [PAL] ICD-609 [NTSC]

Specifications

Image Sensor	1/3" Interline Transfer CCD	
Effective Pixels	PAL : Approx. 440,000 pixels, Effective 752 (H) x 582 (V) NTSC : Approx. 380,000 pixels, Effective 768 (H) x 494 (V)	
Scanning System	PAL : 625 lines at 50Hz, 2:1 interlace NTSC : 525 lines at 59.94Hz, 2:1 interlace	
Synchronization System	Internal Crystal Lock/Line Lock	
Video Output	VBS 1.0Vp-p/75ohm	
Horizontal Resolution	540 TV Lines (Colour Mode) 570 TV Lines (Monochrome Mode)	
S/N Ratio	52dB or better (Standard Illumination, Luminance Signal, Detail off)	
Minimum Illumination (AGC ON)	Type 31	Type 92
	In colour mode : (Video Output 50 IRE)	
	0.8lx/F1.2	1.2lx/F1.5
	In monochrome mode : (Video Output 50 IRE)	
	0.16lx/F1.2	0.24lx/F1.5
In monochrome mode : (Video Output 25 IRE)	0.08lx/F1.2	0.12lx/F1.5
Day/Night Change-over Function	Built-in, AUTO/COLOUR selectable	
AGC (Automatic Gain Control)	Built-in	
White Balance	Automatic Tracking White Balance	
Detail Correction	Built-in	
BLC (Back Light Compensation)	ON/OFF switchable	
AES (Automatic Electronic Shutter)	ON/OFF switchable AES range: PAL: Approx. 1:2000, NTSC: Approx. 1:1600	
Auto Iris function	DC iris	
Focus EZ	Built-in	
Monitor Output Selection	CRT/LCD switchable	
Built-in Lens	Focal Distance	
	Type 31 : f2.9~10mm / Type 92 : f9~22mm	
	Angle Adjustment	
	Horizontal : ±90° Vertical : 40°~140°	
Power Requirement	PAL : AC24V±10%/DC12V (10.5V~28V)	
	NTSC : AC24V±10%/DC12V (10.5V~28V)	
Power Consumption	AC24V : 4.0W or less	
	DC12V : 3.8W or less	
Operating Ambient Temperature	-10°C~+50°C	
Operating Ambient Humidity	30%~90%RH (non-condensing)	
External Dimensions	φ131 X H114mm (without projection)	
Weight	Approx. 640g	



ICD-609PVR / ICD-609VR
1/3"CCD Vandal Resistant
True Day/Night Dome Camera

Dimensions:mm

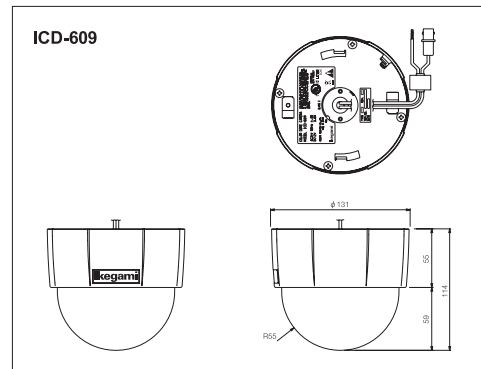
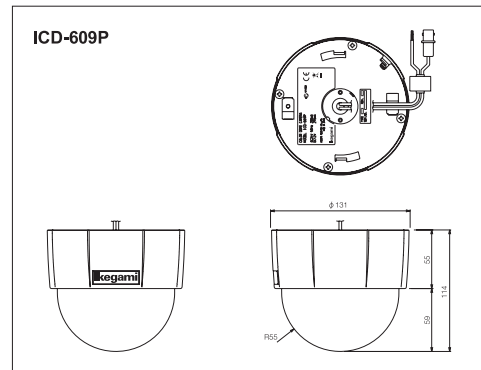

* This product is made of ECO friendly components based upon the Company policy and Corporate Social Responsibility to help Global Environmental solution for energy conservation and environmental sustainability, and all the components used in this product are Non-hazardous, Toxic Free, Non-Lead materials and parts conforming with Japan's Green Product Regulation, EU's RoHS Directive, and other environmental and hazardous chemical substances related regulations and laws.



RoHS
RoHS Compliant

Design and specifications are subject to change without notice.

*NTSC versions are no available with CE Mark.

Ikegami IKEGAMI ELECTRONICS (U.S.A.), INC. ■ URL <http://www.ikegami.com>

HEADQUARTERS 37 BROOK AVENUE, MAYWOOD, NJ 07607
Phone:(201) 368-9171 Fax:(201) 569-1626

WESTCOAST OFFICE 2631 MANHATTAN BEACH BLVD., REDONDO BEACH, CA 90278
Phone:(310) 297-1900 Fax:(310) 536-9550

SOUTHWEST OFFICE 773 BEARDEN WAXAHACHIE, TX 75167 Phone:(972) 869-2363 Fax:(972) 556-1057

MIDWEST OFFICE 747 CHURCH ROAD, UNIT C1, ELMHURST, IL 60126 Phone:(630) 834-9774 Fax:(630) 834-8689

SOUTHEAST OFFICE 5200 N.W. 33RD AVENUE, SUITE 111 FORT LAUDERDALE, FL 33309 Phone:(954) 735-2203 Fax:(954) 735-2227



Accredited by the Dutch Council for Certification

U154A086-HI